

Rosengrens Vertical Binder – 31"

Two-hour fire protection of documents



Rosengrens Vertical Binder is a range of extremely low-weight filing cabinets designed for the storage of ring binders. The cabinet has been tested, approved and certified for two hours' fire protection of paper documents. Vertical Binder is available with 3 or 4 drawers. Each drawer is independently insulated and can be fully opened to allow maximum access to its contents. The range is constructed for strength and stability, with an anti-tipping device and central locking.

Rosengrens Vertical Binder – 31"

Two-hour fire protection of documents

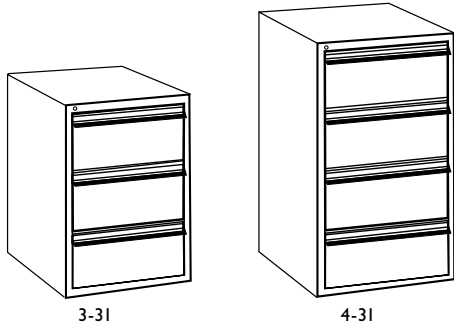

Product data								
Model Vertical Binder	External dimensions (mm)			Internal dimensions (mm)*			Weight (kg)	Capacity (binders)
	Height	Width	Depth	Height	Width	Depth		
3-31	1208	729	771	325	637	660	328	66
4-31	1590	729	771	325	637	660	416	88

*Each drawer's internal dimensions

Fire protection: Rosengrens Vertical Binder filing cabinets have been tested and certified by SP (Technical Research Institute of Sweden) in accordance with the NT Fire 017 – 120 Paper standard. With external temperatures in excess of 1000°C, the test procedure exposes the cabinet to fire for two hours, after which time the documents inside remain unharmed.

For extra protection, Vertical Binder has a day-catch fitted to each drawer. This ensures that as long as a drawer has been pushed shut, its contents are completely protected from fire, even if the cabinet is unlocked. Furthermore, should the filing cabinet be exposed to a fire and one of the drawers has been left open, the contents of the closed drawers still remain completely protected.

Locks: The Vertical Binder range has a central, high-quality key lock which locks all drawers simultaneously.

Design: Considering the level of fire protection provided, Vertical Binder has extremely thin walls. This not only maximises the filing cabinet's storage capacity, but also reduces its weight, making transportation and installation much easier and cheaper.

The filing cabinet also has special high-strength slides allowing the drawers to be pulled out 110% for optimum access to their contents. To prevent tipping, an interlocking system only allows one drawer to be pulled out at a time. In addition, Vertical Binder has been designed to suit the majority of office spaces.

Quality and Environmental Management Systems: Vertical Binder is manufactured in accordance with ISO 9001 for quality management systems and ISO 14001 for environmental management systems.

Rosengrens Product Guidelines: Vertical Binder has been tested and approved in accordance with Rosengrens Product Guidelines, based on all relevant European standards. The aim is to check user-friendliness, safety and product lifecycle, as an assurance to customers that our products will live up to the highest expectations.

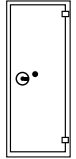
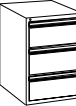
Capacity Comparison	
	<p>Document cabinet 1 Ext. dimensions (mm): 1403x890x664 Weight (kg): 458 No. of binders: 37</p>
	<p>Document cabinet 2 Ext. dimensions: 1930x780x620 Weight: 455 No. of binders: 50</p>
	<p>Vertical Binder Ext. dimensions: 1208x729x771 Weight: 328 No. of binders: 66</p>

*Based on binder with a 60mm-wide spine.